

1

2

3

4

5

6

A

A

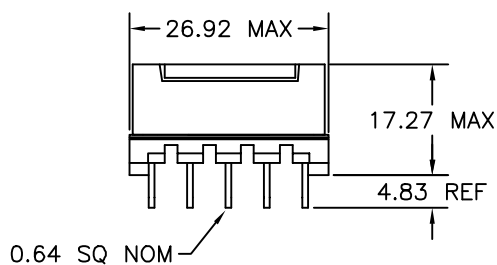

B

B

C

C

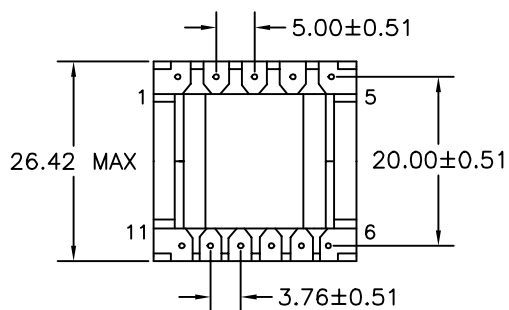

D

D

E

E

ELECTRICAL SPECIFICATIONS

L @ 1kHz 10mA - (5-3) 1.1mH ±10%

LL @ 100kHz 10mA - (5-3) 7.00µH MAX
(WITH 1,2,6-11 SHORTED)

TURNS RATIO - ±3%

N1/N5:N2 - 1:0.136

N1/N5:N3 - 1:0.136

N1/N5:N4 - 1:0.136

DCR - OHMS MAX

N1/N5 - 1.02

N2 - 0.148

N3 - 0.149

N4 - 0.149

HIPOT - 4000VAC 1SEC

N1,N3,N5 TO N2,N4

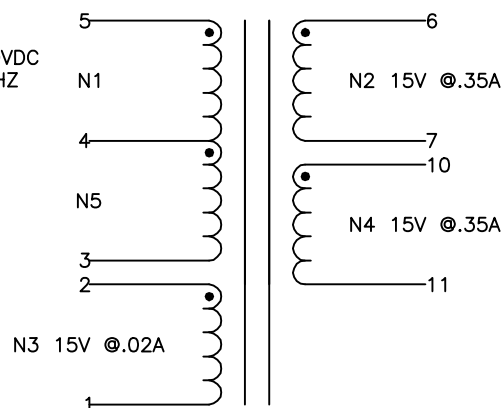
100-400VDC
@ 100KHZ
50% DCNOTE:
POLARITY SHOWN IS FOR THE
TRANSFORMER. FOR CORRECT
FLYBACK OPERATION CONNECT
B+ TO PIN 3.

F

F

G

G

H

H

REVISION		DATE	MARKINGS CRAMER DATE CODE CVP 53-013	LOCATION PIN RAIL SIDE OF CORE
O	PRELIMINARY	04/07/04		
A	RELEASED	04/09/04	DESCRIPTION VIPER 53 FLYBCK XFMR 15,15	TOLERANCE UNLESS OTHERWISE SPECIFIED 2 PLACE DECIMALS ±.010 3 PLACE DECIMALS ±.005 FRACTIONS ±1/64 ANGLES ±1/2°
B	UPDATED SCHMATIC N2 WAS 6-8, N4 WAS 9-11	04/20/04	CUSTOMER	
C	ADD DCR & LL TOLERANCES PER ECO #5187	10/05/04		
			G:\DATA\SPECS\ENG\CVP\53-013	CUSTOMER PART NUMBER
			DR. MEC	DATE 04/07/04
			APPD. JDB	DATE 04/09/04
				CRAMER PART NUMBER CVP 53-013
				REV C

J

J

1

2

3

4

5

6