

1

2

3

4

5

6

A

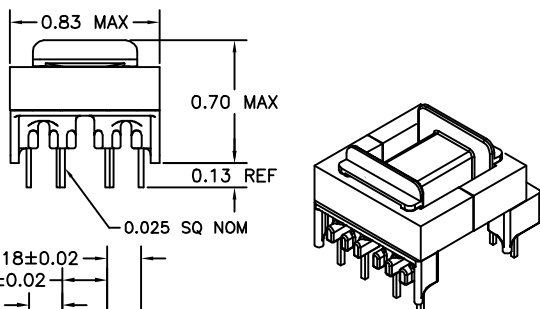

FOR USE WITH
STMicroelectronics
VIPer 50
SECONDARY REGULATION

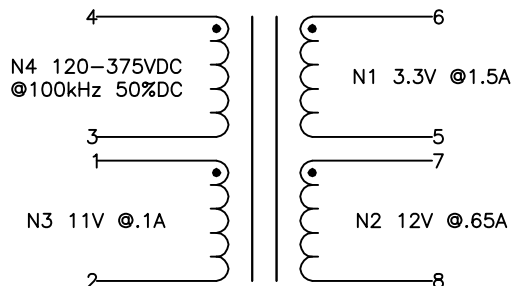

B

C

D

E

ELECTRICAL SPECIFICATIONS

L @ 1kHz .1V - (3-4) 900µH ±10%

LL @ 100kHz .1V - (3-4) 19µH TYP, TOL TBD
(WITH 1,2,5-8 SHORTED)

URNS RATIO - ±3%
3-4:1-2 - 1:0.136
3-4:5-6 - 1:0.045
3-4:7-8 - 1:0.16

DCR - OHMS TYP, TOL TBD
3-4 - 1.73
1-2 - 0.22
5-6 - 0.006
7-8 - 0.06

HIPOT - 5500VAC 1SEC
N1,N2 TO N3,N4

NOTE:
POLARITY SHOWN IS THE TRANSFORMER.
FOR CORRECT FLYBACK OPERATION
CONNECT B+ TO PIN 3.

NOTE:
MEETS CONSTRUCTION FOR:
UL 1310, 1950, 1411
IEC 61558-1, 2-17, EN60950

F

G

H

REVISION		DATE	MARKINGS	LOCATION	
0	PRELIMINARY	01/10/00	CRAMER EIA DATE CODE CVP 30-015	PIN RAIL SIDE OF CORE	
1	CHANGED PIN OUTS	02/22/00	DESCRIPTION 15 VA FLYBACK,3,3,12	TOLERANCE UNLESS OTHERWISE SPECIFIED 2 PLACE DECIMALS ±.010 3 PLACE DECIMALS ±.005 FRACTIONS ±1/64 ANGLES ±1/2°	PROPRIETARY INFORMATION PROPERTY OF CRAMER COIL & TRANSFORMER CO. DUPLICATION AND/OR DISTRIBUTION BY PERMISSION ONLY
			CUSTOMER		
			G:\DATA\SPECS\ENG\CVP\30-015		
			DR. CAM	DATE 01/10/00	CUSTOMER PART NUMBER
			APPD. JDB	DATE 01/11/00	REV
				CRAMER PART NUMBER CVP 30-015	REV 1

J

1

2

3

4

5

6

A

B

C

D

E

F

G

H

I

J